

# CDB650

Connectivity

**SICK**  
Sensor Intelligence.



---

**Described product**

CDB650

**Manufacturer**

SICK AG  
Erwin-Sick-Str. 1  
79183 Waldkirch  
Germany

**Legal information**

This work is protected by copyright. Any rights derived from the copyright shall be reserved for SICK AG. Reproduction of this document or parts of this document is only permissible within the limits of the legal determination of Copyright Law. Any modification, abridgment or translation of this document is prohibited without the express written permission of SICK AG.

The trademarks stated in this document are the property of their respective owner.

© SICK AG. All rights reserved.

**Original document**

This document is an original document of SICK AG.



## Contents

<b>1</b>	<b>About this document.....</b>	<b>5</b>
1.1	Information on the operating instructions.....	5
1.2	Explanation of symbols.....	5
1.3	Further information.....	6
<b>2</b>	<b>Safety information.....</b>	<b>7</b>
2.1	Intended use.....	7
2.2	Improper use.....	7
2.3	Limitation of liability.....	7
2.4	Modifications and conversions.....	8
2.5	Requirements for skilled persons and operating personnel.....	8
<b>3</b>	<b>Product description.....</b>	<b>9</b>
3.1	Configuration elements and displays.....	9
<b>4</b>	<b>Transport and storage.....</b>	<b>11</b>
4.1	Transport.....	11
4.2	Transport inspection.....	11
4.3	Storage.....	11
<b>5</b>	<b>Mounting.....</b>	<b>12</b>
5.1	Commissioning requirements.....	12
5.2	Mounting the connection module.....	12
<b>6</b>	<b>Electrical installation.....</b>	<b>13</b>
6.1	Data interfaces.....	13
6.2	Supply voltage $U_{IN}$ .....	13
6.3	Prerequisites for safe operation of the device.....	13
6.4	Wiring of the connection module.....	16
6.5	Terminal assignment.....	17
6.6	Connecting an external illumination unit for the Lector65x.....	18
<b>7</b>	<b>Maintenance.....</b>	<b>20</b>
7.1	Maintenance plan.....	20
7.2	Cleaning.....	20
<b>8</b>	<b>Troubleshooting.....</b>	<b>21</b>
8.1	Returns.....	21
8.2	Repairs.....	21
<b>9</b>	<b>Technical data.....</b>	<b>22</b>
9.1	Dimensional drawing.....	23
<b>10</b>	<b>Accessories.....</b>	<b>24</b>
<b>11</b>	<b>Appendix.....</b>	<b>25</b>

11.1	EU declaration of conformity/Certificates.....	25
11.2	UL conformity.....	25

# 1 About this document

## 1.1 Information on the operating instructions

These operating instructions provide important information on how to use devices from SICK AG.

Prerequisites for safe work are:

- Compliance with all safety notes and handling instructions supplied.
- Compliance with local work safety regulations and general safety regulations for device applications

The operating instructions are intended to be used by qualified personnel and electrical specialists.



### NOTE

Read these operating instructions carefully to familiarize yourself with the device and its functions before commencing any work.

The operating instructions are an integral part of the product. Store the instructions in the immediate vicinity of the device so they remain accessible to staff at all times. Should the device be passed on to a third party, these operating instructions should be handed over with it.

These operating instructions do not provide information on operating the machine or system in which the device is integrated. Information on this can be found in the operating instructions for the machine or system.

## 1.2 Explanation of symbols

Warnings and important information in this document are labeled with symbols. Signal words introduce the instructions and indicate the extent of the hazard. To avoid accidents, damage, and personal injury, always comply with the instructions and act carefully.



### DANGER

... indicates a situation of imminent danger, which will lead to a fatality or serious injuries if not prevented.



### WARNING

... indicates a potentially dangerous situation, which may lead to a fatality or serious injuries if not prevented.



### CAUTION

... indicates a potentially dangerous situation, which may lead to minor/slight injuries if not prevented.



### NOTICE

... indicates a potentially harmful situation, which may lead to material damage if not prevented.



### NOTE

... highlights useful tips and recommendations as well as information for efficient and trouble-free operation.

## 1.3 Further information

---



### NOTE

Further documentation for the device can be found on the online product page at:

- [www.sick.com/CDB](http://www.sick.com/CDB)

There, additional information has been provided depending on the product, such as:

- Model-specific online data sheets for device types, containing technical data, dimensional drawing, and specification diagrams
  - EU declaration of conformity and certificates for the product family
  - Dimensional drawings and 3D CAD dimension models of the device types in various electronic formats
  - Other publications related to the devices described here
  - Publications dealing with accessories
-

## 2 Safety information

### 2.1 Intended use

Basic connection module for connecting a SICK identification sensor (ID sensor) to a host, CAN sensor network, peripheral devices, and voltage supply. To do so, the ID sensor needs to be connected to the externally accessible M12 female connector of the connection module using a SICK standard cable. The voltage supply is delivered via cable glands and terminals, and the signals are distributed on cables.

#### Supported ID sensors

- Fixed mount bar code scanner CLV62x to CLV64x (type-dependent), CLV69x
- Lector® series
- RFID read/write device

### 2.2 Improper use

Any use outside of the stated areas, in particular use outside of the technical specifications and the requirements for intended use, will be deemed to be incorrect use.

- The device does not constitute a safety component in accordance with the respective applicable safety standards for machines.
- The device must not be used in explosion-hazardous areas, in corrosive environments or under extreme environmental conditions.
- Any use of accessories not specifically approved by SICK AG is at your own risk.



#### WARNING

##### Danger due to improper use!

Any improper use can result in dangerous situations.

Therefore, observe the following information:

- Product should be used only in accordance with its intended use.
- All information in these operating instructions must be strictly observed.
- Shut down the product immediately in case of damage.

### 2.3 Limitation of liability

Relevant standards and regulations, the latest technological developments, and our many years of knowledge and experience have all been taken into account when compiling the data and information contained in these operating instructions. The manufacturer accepts no liability for damage caused by:

- Non-adherence to the product documentation (e.g., operating instructions)
- Incorrect use
- Use of untrained staff
- Unauthorized conversions or repair
- Technical modifications
- Use of unauthorized spare parts, consumables, and accessories

With special variants, where optional extras have been ordered, or owing to the latest technical changes, the actual scope of delivery may vary from the features and illustrations shown here.

## 2.4 Modifications and conversions



### NOTICE

Modifications and conversions to the device may result in unforeseeable dangers.

Interrupting or modifying the device or SICK software will invalidate any warranty claims against SICK AG. This applies in particular to opening the housing, even as part of mounting and electrical installation.

## 2.5 Requirements for skilled persons and operating personnel



### WARNING

#### Risk of injury due to insufficient training.

Improper handling of the device may result in considerable personal injury and material damage.

- All work must only ever be carried out by the stipulated persons.

This product documentation refers to the following qualification requirements for the various activities associated with the device:

- **Instructed personnel** have been briefed by the operator about the tasks assigned to them and about potential dangers arising from improper action.
- **Skilled personnel** have the specialist training, skills, and experience, as well as knowledge of the relevant regulations, to be able to perform tasks delegated to them and to detect and avoid any potential dangers independently.
- **Electricians** have the specialist training, skills, and experience, as well as knowledge of the relevant standards and provisions, to be able to carry out work on electrical systems and to detect and avoid any potential dangers independently. The electrician must comply with the provisions of the locally applicable work safety regulation.

The following qualifications are required for various activities:

Table 1: Activities and technical requirements

Activities	Qualification
Mounting, maintenance	<ul style="list-style-type: none"> <li>■ Basic practical technical training</li> <li>■ Knowledge of the current safety regulations in the workplace</li> </ul>
Electrical installation, device replacement	<ul style="list-style-type: none"> <li>■ Practical electrical training</li> <li>■ Knowledge of current electrical safety regulations</li> <li>■ Knowledge of the operation and control of the devices in their particular application</li> </ul>
Commissioning, configuration	<ul style="list-style-type: none"> <li>■ Basic knowledge of the computer operating system used</li> <li>■ Basic knowledge of the design and setup of the described connections and interfaces</li> <li>■ Basic knowledge of data transmission</li> </ul>
Operation of the device for the particular application	<ul style="list-style-type: none"> <li>■ Knowledge of the operation and control of the devices in their particular application</li> <li>■ Knowledge of the software and hardware environment for the particular application</li> </ul>



### 3 Product description

- Module for connecting an ID sensor
- Base module for accommodating an optional CMC600 (Connection Module Cloning) for external storage of ID sensor configuration parameters. Also used to activate operating modes as well as to extend the ID sensor by 2 digital switching inputs and 2 switching outputs (depending on the sensor type).
- Integrated trigger unit (load switch) for the Lector65x image-based code reader to activate an external illumination unit that does not have a trigger input
- 17-pin M12 female connector for connecting the ID sensor, supplied with plug to maintain enclosure rating IP65
- Internal 9-pin D-Sub male connector, for connecting the serial AUX interface (RS-232) of the ID sensor to a computer (configuration and diagnostics)
- Terminals for serial host interface, CAN bus, switching inputs and switching outputs, trigger unit, voltage supply, shielding
- Visible through the cover: LEDs for displaying active switching inputs and switching outputs as well as the positions of the configuration switches

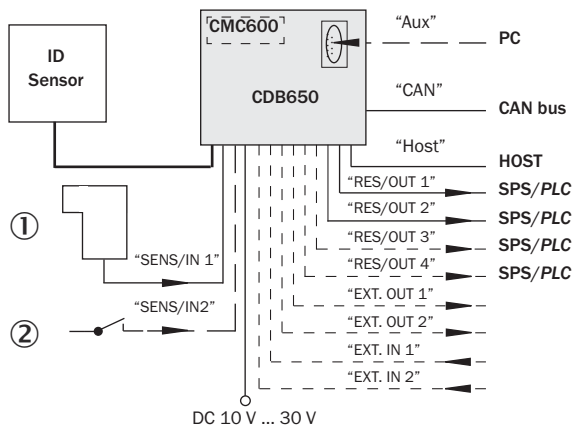

- ① Photoelectric sensor (read cycle)
- ② Switch

#### 3.1 Configuration elements and displays

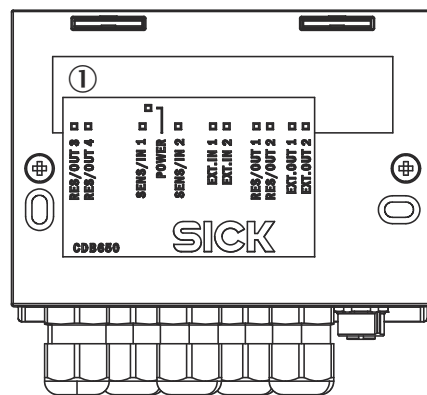

- ① LED display with label

#### Function of the configuration switches

Switch	Function	Default
S 1 (Power)	Supply voltage applied: <ul style="list-style-type: none"> <li>• ON: Supply voltage on</li> <li>• OFF: Supply voltage off</li> </ul>	ON
S2 (Term CAN)	CAN bus termination: <ul style="list-style-type: none"> <li>• ON: 120 Ohm resistor connected</li> <li>• OFF: no termination</li> </ul>	OFF
S 3 (SGND-GND)	Reference potential for sensor GND: <ul style="list-style-type: none"> <li>• ON: Connected to GND of the ID sensor</li> <li>• OFF: Volt-free</li> </ul>	OFF
S4 (CMC)	Integration of the CMC600: <ul style="list-style-type: none"> <li>• "YES": CMC600 connected in the cable of the AUX interface of the ID sensor</li> <li>• "NO": No CMC600 inserted</li> </ul>	NO
S 6 (RS422/485)	RS-422/485 switching <ul style="list-style-type: none"> <li>• ON: RS-485</li> <li>• OFF: RS-422</li> </ul>	OFF
S 7 (Term 485)	RS-485 termination (receiver) <ul style="list-style-type: none"> <li>• ON: 120 Ohm resistor connected</li> <li>• OFF: no termination</li> </ul>	OFF

#### Function of the LEDs

LED	Color	Function
Power	Green	Lights up when operating voltage is supplied to the connection module and switch S 1 is set to "ON"
SENS/IN 1 , SENS/IN 2	Green	Lights up when the corresponding input of the ID sensor is activated
EXT. IN 1 <sup>1)</sup> EXT. IN 2 <sup>1)</sup>	Green	Lights up when the corresponding additional input of the ID sensor (via CMC600) is activated
RES/OUT 1... RES/OUT 4	Orange	Lights when the corresponding output of the ID sensor is present and activated
EXT.OUT 1 <sup>1)</sup> EXT.OUT 2 <sup>1)</sup>	Orange	Lights up when the corresponding additional output of the ID sensor (via CMC600) is activated

<sup>1)</sup> The CMC600 module is a prerequisite.

## 4 Transport and storage

### 4.1 Transport

For your own safety, please read and observe the following notes:



#### NOTICE

##### Damage to the product due to improper transport.

- The device must be packaged for transport with protection against shock and damp.
- Recommendation: Use the original packaging as it provides the best protection.
- Transport should be performed by trained specialist staff only.
- The utmost care and attention is required at all times during unloading and transportation on company premises.
- Note the symbols on the packaging.
- Do not remove packaging until immediately before you start mounting.

### 4.2 Transport inspection

Immediately upon receipt in Goods-in, check the delivery for completeness and for any damage that may have occurred in transit. In the case of transit damage that is visible externally, proceed as follows:

- Do not accept the delivery or only do so conditionally.
- Note the scope of damage on the transport documents or on the transport company's delivery note.
- File a complaint.



#### NOTE

Complaints regarding defects should be filed as soon as these are detected. Damage claims are only valid before the applicable complaint deadlines.

### 4.3 Storage

Store the device under the following conditions:

- Do not store outdoors.
- Store in a dry area that is protected from dust.
- Do not expose to any aggressive substances.
- Protect from sunlight.
- Avoid mechanical shocks.
- Storage temperature: see "Technical data", page 22.
- For storage periods of longer than 3 months, check the general condition of all components and packaging on a regular basis.

### 5 Mounting

#### 5.1 Commissioning requirements

- Computer with Internet access to download connection diagrams in the respective ID sensor product documentation, accessible as a PDF on the ID sensor product page on the web (visit [www.sick.com](http://www.sick.com) and enter the relevant product name in the search).
- Supply voltage: see "Technical data", page 22 and type label of the ID sensor to be connected
- Only perform mounting, connection, and configuration work within the ambient temperature range of 0 °C to +50 °C!
- Use within the ambient temperature range 0 °C to -40 °C only when at rest (no mounting, connection, or configuration work).

#### 5.2 Mounting the connection module

- Can be mounted with the cover closed.
  - Unobstructed access to the internal **AUX** male connector is required at all times in order to access the ID sensor via RS-232 (configuration and diagnostics)
  - Maximum length of cable between the connection module and ID sensor when using the serial data interfaces: 10 m
  - Removable cover with connection diagram can be rotated 180° and locked in parking position
1. Hole and housing dimensions, see "Dimensional drawing", page 23, max. screw diameter: 4 mm.
  2. For installation and commissioning of the optional CMC600, refer to the CMC600 operating instructions at [www.sick.com](http://www.sick.com).

## 6 Electrical installation

### 6.1 Data interfaces

Recommended max. length of cable from the ID sensor to host:

Interface type	Data transmission rate	Distance to host
RS-232	Up to 19.2 kBd 38.4 kBd ... 57.6 kBd	Max. 10 m Max. 3 m
RS-422	Max. 38.4 kBd Max. 57.6 kBd	Max. 1,200 m Max. 500 m

#### Additional switching inputs and switching outputs

The additional function of the CMC600 supports the following ID sensors:

ID sensor	Additional inputs	Additional outputs
CLV69x / RFU63x / LECTOR65x	2	2

### 6.2 Supply voltage $U_{IN}$

The supply voltage level required depends on the ID sensor to be connected (see also the specifications on the ID sensor type label):

ID sensor	Supply voltage
CLV69x	DC 18 V ... 30 V
Lector65x	DC 24 V $\pm$ 20 %
RFU63x	DC 18 V ... 30 V

### 6.3 Prerequisites for safe operation of the device



#### WARNING

#### Risk of injury and damage caused by electrical current!

As a result of equipotential bonding currents between the device and other grounded devices in the system, faulty grounding of the device can give rise to the following dangers and faults:

- Dangerous voltages are applied to the metal housings.
- Devices will behave incorrectly or be destroyed.
- Cable shielding will be damaged by overheating and cause cable fires.

#### Remedial measures

- Only skilled electricians should be permitted to carry out work on the electrical system.
- If the cable insulation is damaged, disconnect the voltage supply immediately and have the damage repaired.
- Ensure that the ground potential is the same at all grounding points.
- Where local conditions do not meet the requirements for a safe earthing method, take appropriate measures. For example, ensure low-impedance and current-carrying equipotential bonding.

The ID sensors (referred to as devices in the rest of this chapter) are each connected to the peripheral devices (PLC, host, read cycle sensor(s), voltage supply, etc.) via a connection module with shielded cables. The cable shield, e.g., of the data cable, is connected to the metal housing of the device and to the terminal strip of the connection module. The connection module can be used to ground the device.

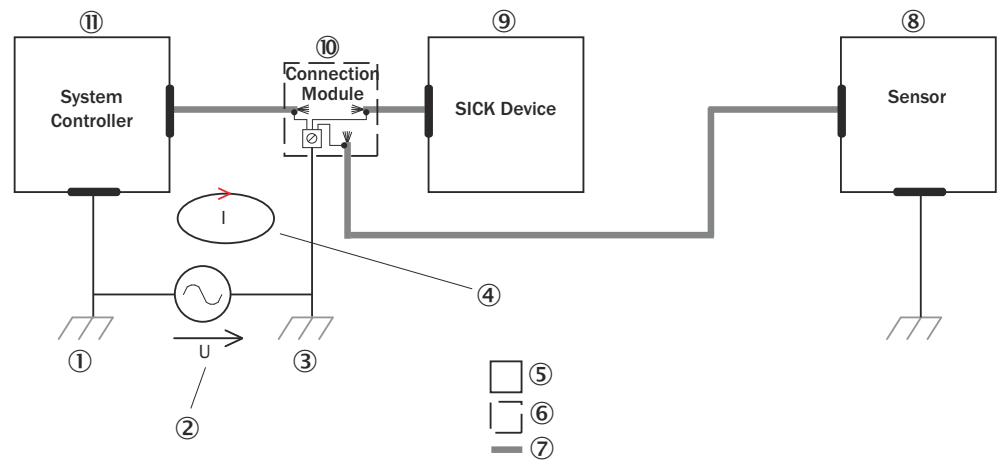

- ① Grounding point 1
- ② Ground potential difference
- ③ Grounding point 2
- ④ Closed current loop with equalizing currents via cable shield
- ⑤ Metal housing
- ⑥ Plastic housing
- ⑦ Shielded electrical cable
- ⑧ Device
- ⑨ Sensor
- ⑩ Connection modules
- ⑪ System controller

If the peripheral devices have metal housings and the cable shields are also in contact with their housings, it is assumed that all devices involved in the installation have the **same ground potential**.

This is achieved by complying with the following conditions:

- Mounting the devices on conductive metal surfaces
- Correctly grounding the devices and metal surfaces in the system
- If necessary: low-impedance and current-carrying equipotential bonding between areas with different ground potentials

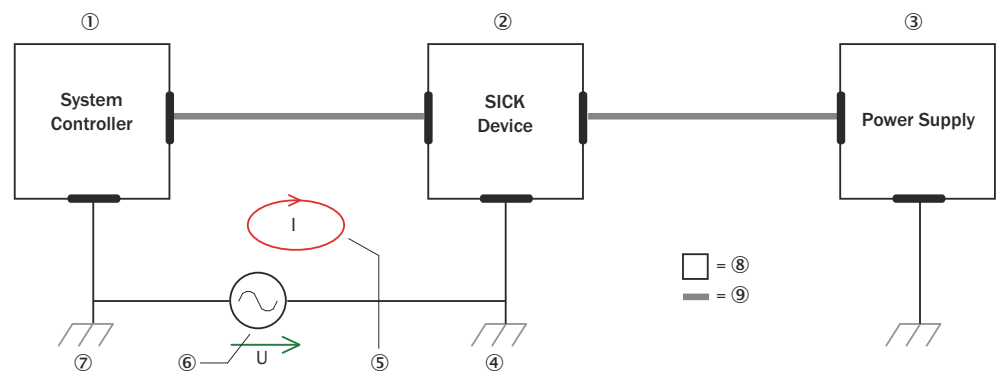

Figure 1: Example: Occurrence of equipotential bonding currents in the system configuration

- ① System controller
- ② Device
- ③ Voltage supply
- ④ Grounding point 2
- ⑤ Closed current loop with equalizing currents via cable shield

- ⑥ Ground potential difference
- ⑦ Grounding point 1
- ⑧ Metal housing
- ⑨ Shielded electrical cable

If these conditions are not fulfilled, equipotential bonding currents can flow along the cable shielding between the devices due to differing ground potentials and cause the hazards specified. This is, for example, possible in cases where there are devices within a widely distributed system covering several buildings.

#### Remedial measures

The most common solution to prevent equipotential bonding currents on cable shields is to ensure low-impedance and current-carrying equipotential bonding. If this equipotential bonding is not possible, the following solution approaches serve as a suggestion.



#### NOTICE

We expressly advise against opening up the cable shields. This would mean that the EMC limit values can no longer be complied with and that the safe operation of the device data interfaces can no longer be guaranteed.

#### Measures for widely distributed system installations

On widely distributed system installations with correspondingly large potential differences, the setting up of local islands and connecting them using commercially available **electro-optical signal isolators** is recommended. This measure achieves a high degree of resistance to electromagnetic interference.

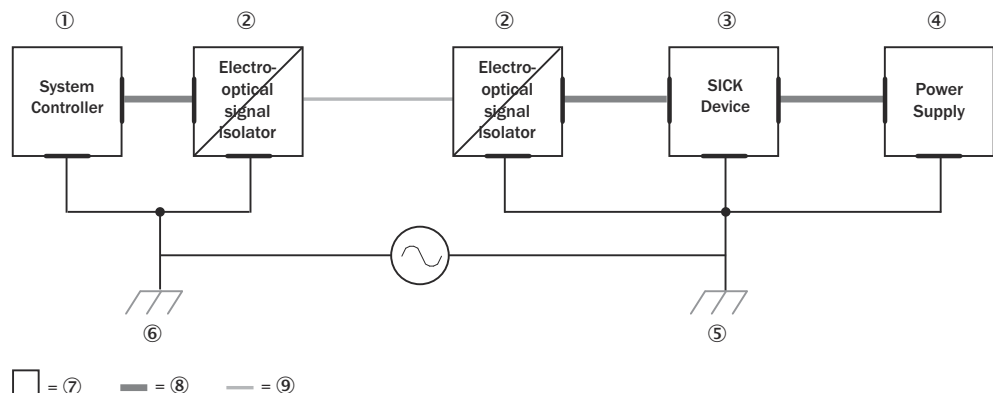

Figure 2: Example: Prevention of equipotential bonding currents in the system configuration by the use of electro-optical signal isolators

- ① System controller
- ② Electro-optical signal isolator
- ③ Device
- ④ Voltage supply
- ⑤ Grounding point 2
- ⑥ Grounding point 1
- ⑦ Metal housing
- ⑧ Shielded electrical cable
- ⑨ Optical fiber

The use of electro-optical signal isolators between the islands isolates the ground loop. Within the islands, a stable equipotential bonding prevents equalizing currents on the cable shields.

### Measures for small system installations

For smaller installations with only slight potential differences, insulated mounting of the device and peripheral devices may be an adequate solution.

Even in the event of large differences in the ground potential, ground loops are effectively prevented. As a result, equalizing currents can no longer flow via the cable shields and metal housing.



---

#### NOTICE

The voltage supply for the device and the connected peripheral devices must also guarantee the required level of insulation.

Under certain circumstances, a tangible potential can develop between the insulated metal housings and the local ground potential.

---

## 6.4 Wiring of the connection module

---



#### WARNING

##### Risk of injury due to electric current!

If the supply voltage is produced by a power supply unit, then insufficient electrical separation between input and output current circuit of the power supply unit may lead to an electric shock.

- Only use a power supply unit whose output circuit has safe electrical separation from the input circuit. For example with a safety transformer in accordance with EN 61558-1.
- 
- Electrical installation must only be carried out by qualified personnel.
  - Standard safety requirements must be observed when working on electrical systems!
  - The voltage supply must be disconnected when attaching or detaching electrical connections.
  - To ensure protection against short-circuits/overload in the outgoing supply cables ( $U_{IN}^*$ ) to the ID sensor, the wire cross-sections used must be suitably dimensioned for the fuse installed in the connection module. Observe the following standards: DIN VDE 0100 (Part 430), DIN VDE 0298 (Part 4) and DIN VDE 0891 (Part 1)
  - For the terminal assignment, see the connection diagram or the inside of the cover.
  - For connection diagrams for the host interface/CAN interface/switching inputs and switching outputs, see the technical information of the relevant ID sensor.
  - To prevent interference, avoid laying the cables parallel to the power supply and motor cables.
  - Select the reference potential for the switching inputs using switch S 3.
1. Connect the 17-pin M12 male connector of the ID sensor to the 17-pin M12 female connector of the connection module via a cable e.g., no. 6051194 (3 m).
  2. Connect all other cables to the terminals via cable glands. Attach blind plugs to all unused bushings.
  3. Optional: Connect the integrated trigger unit for the external illumination unit of the Lector65x see "[Connecting an external illumination unit for the Lector65x](#)", page 18.
  4. Connect the customer's shield to the connection module ("Shield" terminal).
  5. CAN bus: If the connection module is located at the end of the bus, connect a termination resistor to switch S 2.



6. Activate the driver for the wired serial host and/or CAN interface in the ID sensor using the SOPAS ET configuration software (see operating instructions of the ID sensor).  
To do so, use a 3-wire RS-232 data line (null modem line) to connect a computer to the "AUX" male connector on the connection module, or contact the ID sensor via Ethernet (depending on the sensor type).
7. Switch on the voltage supply to the connection module.

## 6.5 Terminal assignment

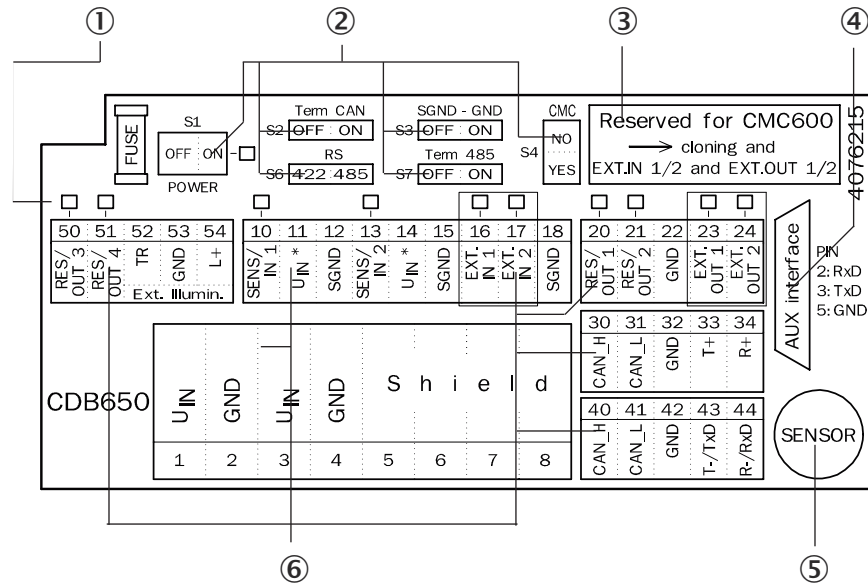

Figure 3: Pin assignment of the terminals and switches

- ① LEDs
- ② Configuration switch
- ③ Slot for CMC600
- ④ PC connection
- ⑤ ID sensor connection
- ⑥ Terminal strips

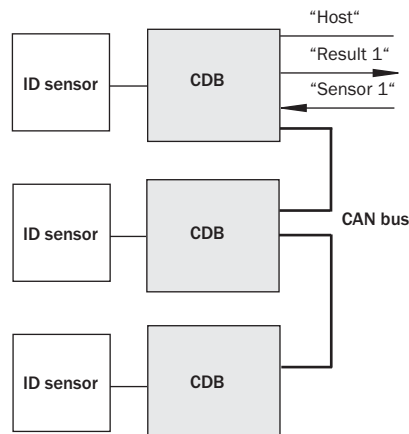

Figure 4: Schematic: Structure of a CAN sensor network

## 6.6 Connecting an external illumination unit for the Lector65x

An external illumination unit with a suitable supply voltage range for the Lector65x can be connected to the connection module, triggered and activated for this purpose in the Lector65x as follows

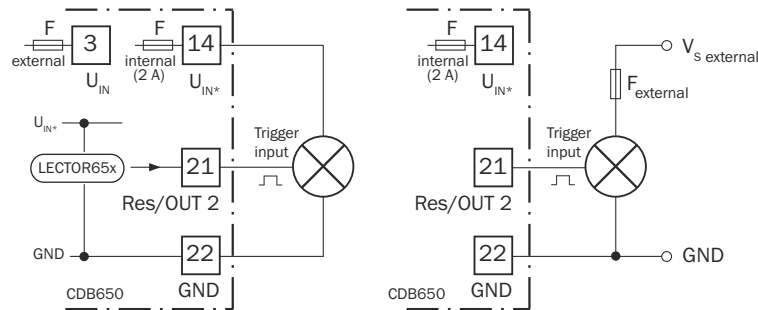

Figure 5: Illumination unit with trigger input

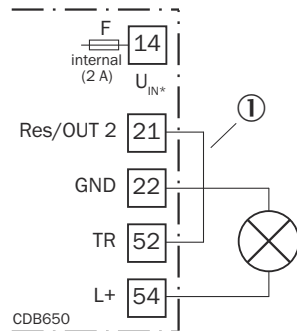

Figure 6: Illumination unit without trigger input

### Connecting an illumination unit with trigger input

The illumination unit (e.g. ICLxxx) must provide flying leads with 3 wires for connection:

- Supply voltage
- GND
- Trigger input

The trigger input of the illumination unit is connected directly to the switching output Res 2 or Res 4 of the Lector65x in the connection module (see figure 5, page 18). The illumination unit is supplied either via a separate external voltage  $V_s$  relative to GND of the connection module, or via the supply voltage applied to the connection module. If the illumination unit is supplied via the terminal  $U_{in}^*$  of the connection module (internally protected with a 2 A fuse), the total current for all loads (internal connection module, Lector65x incl. switching output Res 2 or Res 4, and illumination unit) must not exceed 1.5 A.

Example: Lector65x consumes 1.05 A at DC 19.2 V with no load at its switching outputs. 1.5 A minus 1.05 A equals a max. available current of 0.45 A for the illumination unit. If, on the other hand, the non-fused terminal  $U_{in}$  of the connection module is used, the customer must protect the supply cables of the illumination unit using a fuse suitable for the wire cross-section.

### Connecting an illumination unit without trigger input

The illumination unit (e.g., VLR) provides flying leads with only 2 wires for connection:

- Supply voltage
- GND

To trigger the illumination unit, its supply voltage is switched on and off via the load switch of the trigger unit installed in the connection module (see figure 6, page 18). The Res 2 or Res 4 switching output of the Lector65x forms the control input circuit for the trigger unit. The supply voltage  $U_{in}^*$  applied internally to the trigger unit is protected by the 2 A fuse of the connection module. The total current for the Lector65x incl. switching output Res 2 or Res 4 and the illumination unit must not exceed 1.5 A.

Example: Lector65x consumes 1.05 A at DC 19.2 V with no load at its switching outputs. 1.5 A minus 1.05 A equals a max. available current of 0.45 A for the illumination unit. An external voltage cannot be connected to the illumination unit.

#### Activating the illumination control in the Lector65x

1. Switch on the supply voltage to the connection module (Lector65x).
2. Set the following parameters in the Lector65x using the **Single Device** option in the SOPAS ET configuration software:
  - Result 2 or Result 4 switching output: Select **External illumination unit** as the light source.
  - Select the illumination unit model based on the available illumination unit (e.g., ICLxxx).
  - For other illumination units (e.g., VLR), select the required signal: **active low** or **active high** . Also set the operating mode to **continuous** or **alternating** (flashing). For detailed instructions, see the Electrical installation chapter in the Lector65x technical information [www.sick.com/Lector65x](http://www.sick.com/Lector65x).

## 7 Maintenance

### 7.1 Maintenance plan

During operation, the device works maintenance-free.

Table 2: Maintenance plan

Maintenance work	Interval	To be carried out by
Check device and connecting cables for damage at regular intervals.	Depends on ambient conditions and climate.	Specialist
Clean housing.	Depends on ambient conditions and climate.	Specialist
Check the screw connections and plug connectors.	Depends on the place of use, ambient conditions or operating requirements. Recommended: At least every 6 months.	Specialist

### 7.2 Cleaning



#### NOTICE

#### Equipment damage due to improper cleaning.

Improper cleaning may result in equipment damage.

- Only use recommended cleaning agents and tools.
- Never use sharp objects for cleaning.

- ▶ The device must be cleaned regularly from the outside to guarantee heat dissipation and therefore operation. Particular attention must be paid to ensure that the cooling ribs and, if present, the fan are free from dust and dirt. Clean using a dry towel or an industrial vacuum cleaner. Do not use cleaning agents.

## 8 Troubleshooting

Fault	Corrective measure
After applying the supply voltage $U_{IN}$ , the "Power" LED ( $U_{IN}^*$ ) does not light up	<ul style="list-style-type: none"> <li>Set switch S 1 (Power) to the "ON" position</li> </ul>
Signals from the connected read cycle sensor continue to have no effect in the ID sensor	<ul style="list-style-type: none"> <li>Connect the read cycle sensor according to the operating instructions of the ID sensor</li> <li>Check the position of switch S 3 (SGND-GND)</li> <li>Set the source of the read cycle in the ID sensor to "Sensor 1" using the SOPAS ET configuration software. Carry out the download to the ID sensor!</li> </ul>
After connecting the PC to the "AUX" male connector, the ID sensor cannot be accessed using the SOPAS ET configuration software	<ul style="list-style-type: none"> <li>If no CMC600 is plugged in, set switch S 4 to the "NO" position</li> <li>If no CMC600 is plugged in, set switch S 4 to the "NO" position</li> <li>SOPAS ET: The required device description file for the relevant ID sensor is not available, or it has a different firmware version than the current device. Reload and integrate a suitable device description file in SOPAS ET via the device catalog.</li> <li>SOPAS ET: Use the "Device search" function to establish communication with the ID sensor</li> </ul>

### 8.1 Returns

- ▶ Only send in devices after consulting with SICK Service.
- ▶ The device must be sent in the original packaging or an equivalent padded packaging.



#### NOTE

To enable efficient processing and allow us to determine the cause quickly, please include the following when making a return:

- Details of the contact person
- Description of the application
- Description of the fault that occurred

### 8.2 Repairs

Repair work on the device may only be performed by qualified and authorized personnel from SICK AG. Interruptions or modifications to the device by the customer will invalidate any warranty claims against SICK AG.

## 9 Technical data

**NOTE**

The relevant online data sheet for your product, including technical data, dimensional drawing, and connection diagrams can be downloaded, saved, and printed from the Internet:

- [www.sick.com/CDB](http://www.sick.com/CDB)

Please note: This documentation may contain further technical data.

Type	CDB650-204 (part no. 1064114)
Optical indicators	11 x LED
Electrical connections	1 x 17-pin M12 female connector, A-coded 1 x internal 9-pin D-Sub male connector Spring-loaded terminals: <ul style="list-style-type: none"> <li>• 8 for 0.14 mm<sup>2</sup> ... 2.5 mm<sup>2</sup> wires</li> <li>• 29 for 0.14 mm<sup>2</sup> ... 1 mm<sup>2</sup> wires</li> </ul>
Cable glands	5 x M16, clamping range 4.5 ... 10 (7) mm
Supply voltage	DC 10 V ... 30 V SELV according to EN 61010 and Class 2 (UL 1310)
Power consumption	1 W
Input current	Max. 2.4 A <sup>1)</sup>
Fuse <sup>2)</sup>	MINI blade fuse, 32 V, 2 A
Housing	Polycarbonate
Trigger unit	Control current: 10 mA, switching current: see " <a href="#">Connecting an external illumination unit for the Lector65x</a> ", page 18
Mark of conformity	CE, UL <sup>3)</sup>
Electrical safety	IEC 61010-1:2010 + Cor.: 2011
Protection class	III
Enclosure rating	IP65 <sup>4)</sup> (EN 60529/A1: 2002-02)
EMC test	EN 61000-6-2: 2005-08 EN 61000-6-3: 2007-01
Vibration resistance	EN 60068-2-6: 2008-02
Shock resistance	EN 60068-2-27: 2009-05
Weight	Approx. 265 g
Ambient temperature	Operation: -40 °C ... +50 °C <sup>5)</sup> Warehouse: -30 °C ... +75 °C
Rel. Air humidity	Max. 90 %, non-condensing

<sup>1)</sup> At terminals U<sub>IN</sub>.

<sup>2)</sup> For voltage U<sub>IN</sub>\*, switched via S 1 and internal fuse.

<sup>3)</sup> Valid with corresponding device identification on the type label.

<sup>4)</sup> When using the SICK sensor standard connection cable.

Enclosure rating not tested by UL.

UL certified when using one of the following power supply units: UL60950-1: LPS or Class 2 (UL1310), UL508: Class 2 (UL1310)

<sup>5)</sup> Ambient operating temperature 0 °C to -35 °C under the following conditions:

- Mounting, electrical connection as well as configuration or power-up of the module via built-in switches only in the normal ambient operating temperature range 0 °C to +40 °C.
- Use at ambient operating temperature 0 °C to -35 °C only when at rest (no mounting, connection, or configuration work on the module).

## 9.1 Dimensional drawing

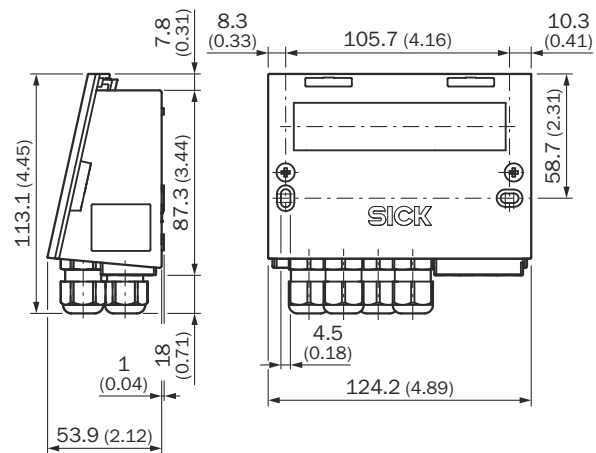

Figure 7: Device dimensions; unit mm (inch), decimal separator: point

- ① Female connector M12, 17-pin
- ②  $\varnothing$  4.5 mm ... 10 mm PG connector (5 x)

## 10 Accessories

---



**NOTE**

Accessories and where applicable mounting information can be found online at:

- [www.sick.com/CDB](http://www.sick.com/CDB)
-



## 11 Appendix

### 11.1 EU declaration of conformity/Certificates

The EU declaration of conformity and other certificates can be downloaded from the Internet at:

- [www.sick.com/CDB](http://www.sick.com/CDB)

### 11.2 UL conformity



NFPA79 applications only. Adapters including field wiring cables are available.

For more information visit:

- ▶ [www.sick.com/CDB](http://www.sick.com/CDB)



#### CAUTION

#### Hazardous radiation!

Using control elements or settings or executing procedures other than those specified in this document may result in dangerous exposure to radiation.

**Australia**

Phone +61 (3) 9457 0600  
1800 33 48 02 – tollfree  
E-Mail sales@sick.com.au

**Austria**

Phone +43 (0) 2236 62288-0  
E-Mail office@sick.at

**Belgium/Luxembourg**

Phone +32 (0) 2 466 55 66  
E-Mail info@sick.be

**Brazil**

Phone +55 11 3215-4900  
E-Mail comercial@sick.com.br

**Canada**

Phone +1 905.771.1444  
E-Mail cs.canada@sick.com

**Czech Republic**

Phone +420 234 719 500  
E-Mail sick@sick.cz

**Chile**

Phone +56 (2) 2274 7430  
E-Mail chile@sick.com

**China**

Phone +86 20 2882 3600  
E-Mail info.china@sick.net.cn

**Denmark**

Phone +45 45 82 64 00  
E-Mail sick@sick.dk

**Finland**

Phone +358-9-25 15 800  
E-Mail sick@sick.fi

**France**

Phone +33 1 64 62 35 00  
E-Mail info@sick.fr

**Germany**

Phone +49 (0) 2 11 53 010  
E-Mail info@sick.de

**Greece**

Phone +30 210 6825100  
E-Mail office@sick.com.gr

**Hong Kong**

Phone +852 2153 6300  
E-Mail ghk@sick.com.hk

**Hungary**

Phone +36 1 371 2680  
E-Mail ertekezes@sick.hu

**India**

Phone +91-22-6119 8900  
E-Mail info@sick-india.com

**Israel**

Phone +972 97110 11  
E-Mail info@sick-sensors.com

**Italy**

Phone +39 02 27 43 41  
E-Mail info@sick.it

**Japan**

Phone +81 3 5309 2112  
E-Mail support@sick.jp

**Malaysia**

Phone +603-8080 7425  
E-Mail enquiry.my@sick.com

**Mexico**

Phone +52 (472) 748 9451  
E-Mail mexico@sick.com

**Netherlands**

Phone +31 (0) 30 229 25 44  
E-Mail info@sick.nl

**New Zealand**

Phone +64 9 415 0459  
0800 222 278 – tollfree  
E-Mail sales@sick.co.nz

**Norway**

Phone +47 67 81 50 00  
E-Mail sick@sick.no

**Poland**

Phone +48 22 539 41 00  
E-Mail info@sick.pl

**Romania**

Phone +40 356-17 11 20  
E-Mail office@sick.ro

**Russia**

Phone +7 495 283 09 90  
E-Mail info@sick.ru

**Singapore**

Phone +65 6744 3732  
E-Mail sales.gsg@sick.com

**Slovakia**

Phone +421 482 901 201  
E-Mail mail@sick-sk.sk

**Slovenia**

Phone +386 591 78849  
E-Mail office@sick.si

**South Africa**

Phone +27 10 060 0550  
E-Mail info@sickautomation.co.za

**South Korea**

Phone +82 2 786 6321/4  
E-Mail infokorea@sick.com

**Spain**

Phone +34 93 480 31 00  
E-Mail info@sick.es

**Sweden**

Phone +46 10 110 10 00  
E-Mail info@sick.se

**Switzerland**

Phone +41 41 619 29 39  
E-Mail contact@sick.ch

**Taiwan**

Phone +886-2-2375-6288  
E-Mail sales@sick.com.tw

**Thailand**

Phone +66 2 645 0009  
E-Mail marcom.th@sick.com

**Turkey**

Phone +90 (216) 528 50 00  
E-Mail info@sick.com.tr

**United Arab Emirates**

Phone +971 (0) 4 88 65 878  
E-Mail contact@sick.ae

**United Kingdom**

Phone +44 (0)17278 31121  
E-Mail info@sick.co.uk

**USA**

Phone +1 800.325.7425  
E-Mail info@sick.com

**Vietnam**

Phone +65 6744 3732  
E-Mail sales.gsg@sick.com

Detailed addresses and further locations at [www.sick.com](http://www.sick.com)